



# RatioMatic Burners

Model RM500

Version 3.10

## Specifications

PARAMETER	SPECIFICATIONS				
Maximum input (Btu/hr)  <b>Note:</b> Contact factory for varying chamber pressures or pressures outside the range: -5.0" to 5.0" w.c. (-12,4 to 12,4 mbar)	<b>Frequency</b>	<b>BTU/hr</b>	<b>"w.c.</b>	<b>kW</b>	<b>mbar</b>
	60 Hz	5,780,000	-5.0	1690	-12,4
	Packaged Blower	5,380,000	-2.0	1580	-5,0
		5,100,000	0.0	1490	0,0
		4,800,000	2.0	1410	5,0
		4,310,000	5.0	1260	12,4
	50 Hz	5,700,000	-5.0	1670	-12,4
	Packaged Blower	5,300,000	-2.0	1550	-5,0
		5,010,000	0.0	1470	0,0
		4,710,000	2.0	1380	5,0
4,210,000		5.0	1230	12,4	
Minimum input		BTU/hr	kW		
		75,000	22		
Main Gas Inlet Pressure		psig		mbar	
- Fuel pressure at ratio regulator inlet	Natural gas	1.0 to 2.0	70 to 140		
	Propane / Butane	1.0 to 1.5	70 to 105		
High Fire Flame Length		inches		mm	
- Measured from the outlet end of combustor	Natural gas	56	1430		
	Propane / Butane	64	1630		
Maximum Chamber Temperature		°F		°C	
	Alloy Tube	1500	820		
	Block & holder	1900	1040		
Flame Detection	Alloy Tube	Flame rod or UV scanner			
	Block & holder	UV scanner only			
Fuel	Natural gas, Propane, or Butane.				
	For any other mixed gas, contact Eclipse Combustion for orifice sizing				

- All information is based on laboratory testing. Different chamber size and conditions will affect the data.
- Maximum inputs are given for the standard combustion air blower without an air filter.
- All inputs based upon gross calorific values and standard conditions; 1 atmosphere, 70° F ( 21°C).
- Eclipse reserves the right to change the construction and/or configuration of our products at any time without being obliged to adjust earlier supplies accordingly.

## Performance Graphs RatioMatic RM500

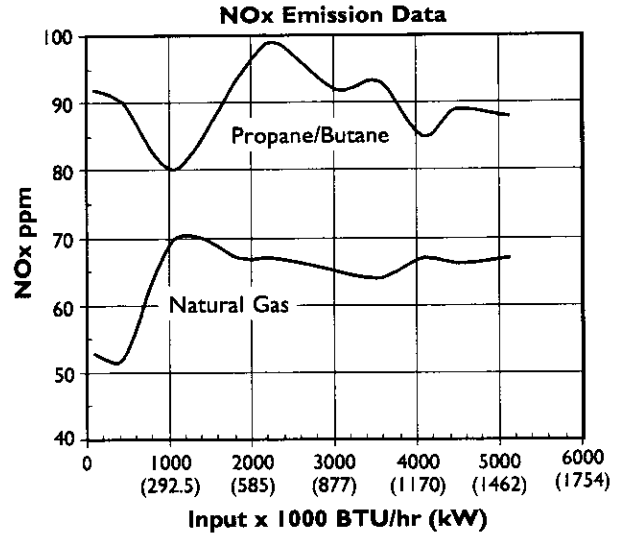
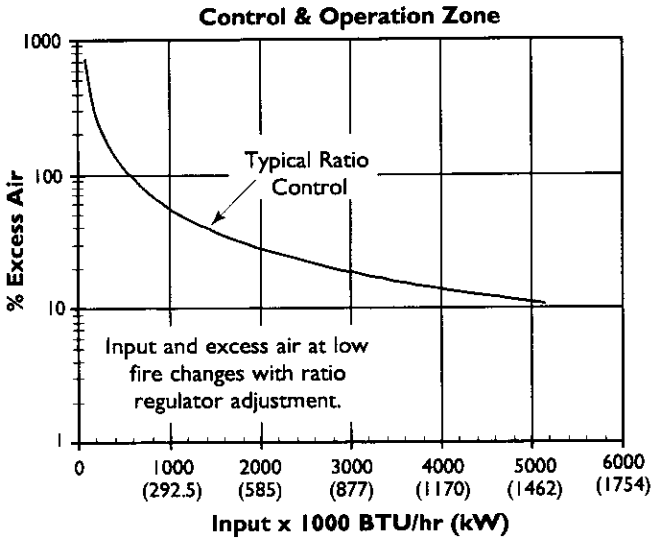

NOx emission data is given for:

- Ambient combustion air ~70° F (20° C)
- Less than 1000° F (540° C) firing chamber
- Minimal process air velocity
- Low fire input adjusted to 75,000 BTU/hr (22kW)
- ppm volume, dry @ 3% O<sub>2</sub>
- Neutral chamber pressure

Emissions are influenced by:

- Chamber conditions
- Fuel type
- Firing rate
- Ratio regulator adjustment
- Combustion air temperature

CO emission is largely influenced by chamber conditions. Contact your local Eclipse Combustion representative for an estimate of CO emission on your application

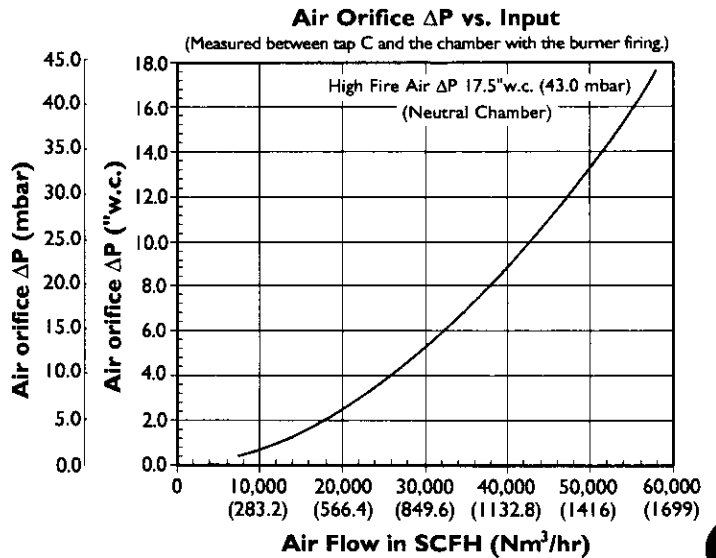
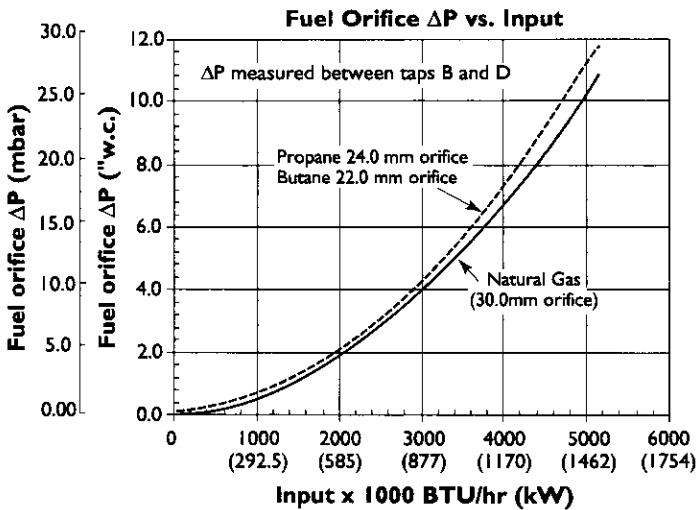

## Dimensions-RM500

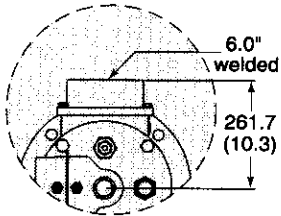
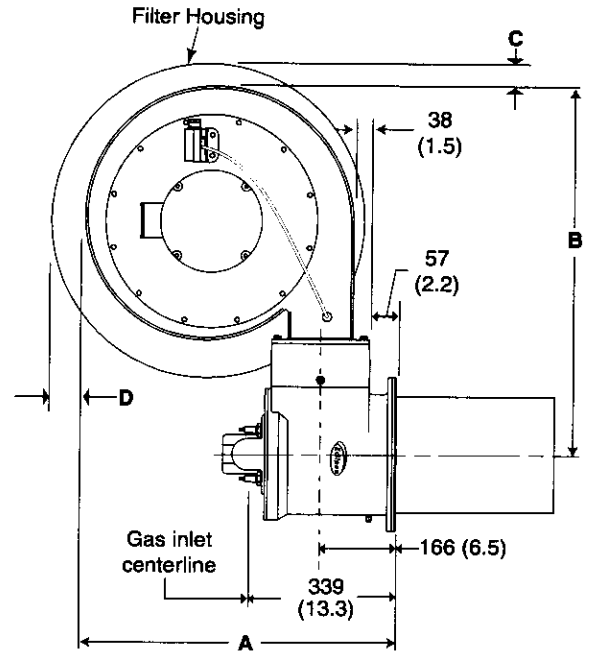
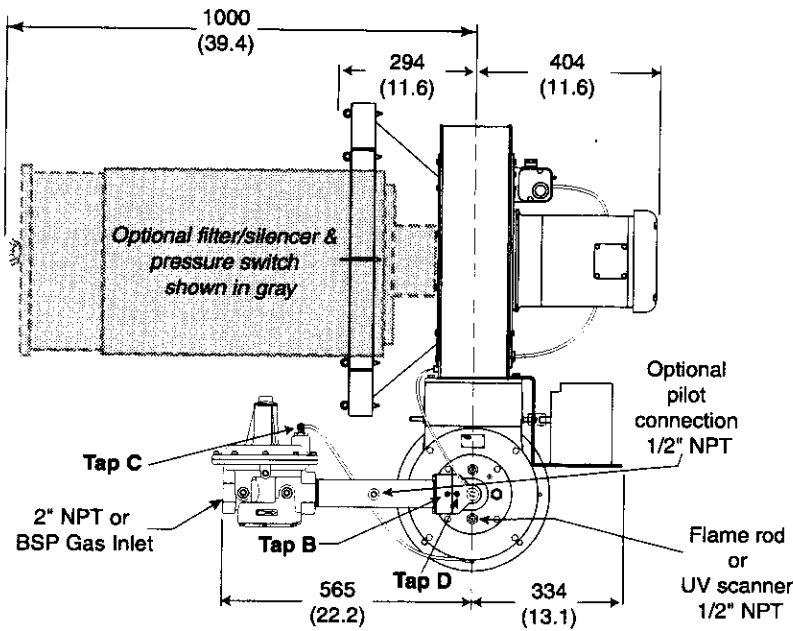

### Weights

Packaged Burner:	109 kg	240 lb
Filter/Silencer:	24 kg	52 lb

Freq.	A	B	C	D
50Hz	698 (27.5)	893 (35.2)	12.5 (0.5)	28.5 (1.1)
60Hz	670 (26.4)	811 (31.9)	44.5 (1.75)	61.5 (2.4)

Less Blower Option

## Combustor types

### Alloy tube

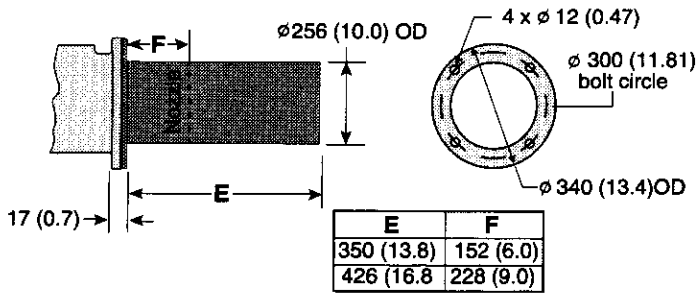

### Block & Holder

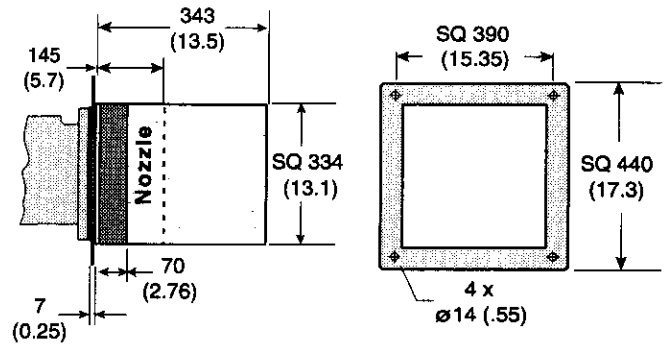

## Burner configuration

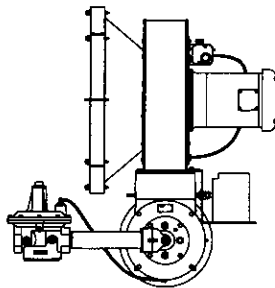

Upright  
left hand piping

Inverted  
left hand piping

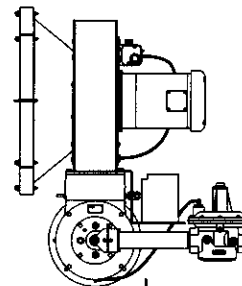
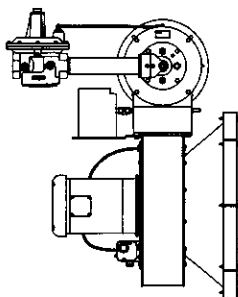

Upright  
right hand piping

Inverted  
right hand piping

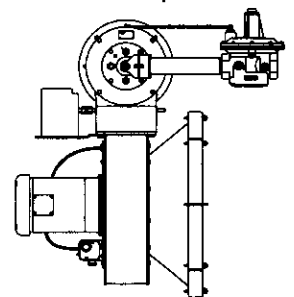



**Offered By:**

Power Equipment Company  
2011 Williamsburg Road  
Richmond, Virginia 23231  
Phone (804) 236-3800  
Fax (804) 236-3882

---

[www.peconet.com](http://www.peconet.com)